



250 Crossways Park Drive, Woodbury, NY 11797 USA • 2 route de Tours, 72500 Château-du-Loir, France • www.infinitysystems.com

A Harman International Company © 2005 Harman International Industries, Incorporated.
All rights reserved. Printed 11/05 Part No. IHCASCADECAT05 EN

Designed, edited and digitally produced by Harman Consumer Group Marketing & Design Center, Woodbury, NY.

Infinity, Harman International, CMMD (patent nos. 6,327,372 and 6,404,897) and Prelude MTS are trademarks of Harman International Industries, Incorporated, registered in the United States and/or other countries.

Cascade, Maximum Radiating Surface, MRS, Room Adaptive Bass Optimization System and R.A.B.O.S. are trademarks of Harman International Industries, Incorporated.



Infinity continually strives to update and improve existing products, as well as create new ones. The specifications and construction details herein are therefore subject to change without notice.



Changing the Shape of Sound... Again.

CASCADE™
SERIES



TECHNOLOGY • PERFORMANCE • DESIGN



68

1968
Servo-Statik 1



72



78

IRS Beta

82



Series III

76

79

85

00



Prelude MTS

98

01

03

05

2005
Cascade™



INTRODUCING CASCADE™

LEGENDARY INFINITY PERFORMANCE.
ENTIRELY NEW FORM FACTOR.

The popularity of flat-panel plasma and LCD video displays ought to suggest at least one certainty about the future of home audio – tomorrow's loudspeakers won't be the boxy, intrusive instruments they often are today. They'll deliver all the power and realism we've come to expect. But they'll be thinner and more elegant than ever before. And the first of this brave new generation? Infinity Cascade™.

Infinity has been advancing the science of sound for more than 35 years with breakthrough audio technologies and landmark loudspeaker systems. Cascade continues the tradition. With patent-pending Maximum Radiating Surface™ (MRS™) flat-panel transducers, Cascade delivers uncompromised Infinity sonic performance from strikingly beautiful speakers.

High-definition flat-panel video, meet high-performance flat-panel audio.

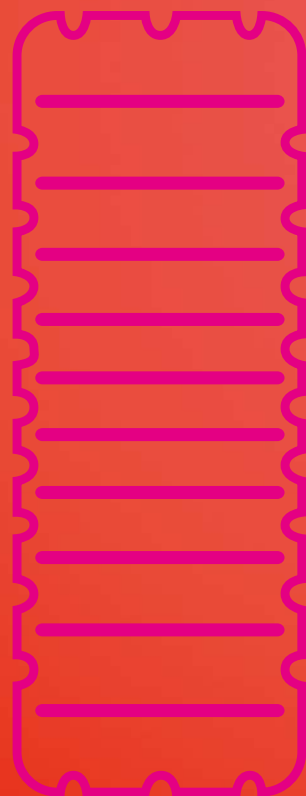

WITH INNOVATIVE FLAT-PANEL
TRANSDUCERS, CASCADE IS MINIMALIST
IN LOOK ONLY.

Imagine you're an audio engineer in search of a new concept, a dramatically less-intrusive loudspeaker design. The problem is that conventional transducer cones, when coupled with their motor assemblies, are nearly as deep as they are wide. And placing a circular cone in a rectangular enclosure results in rather a lot of wasted space in all directions.

Now imagine you're an audio engineer at Infinity, a company with nearly 30 years of experience with electromagnetic induction (EMI) transducers to guide your work. If you could combine the flat, rectangular diaphragm of an EMI device with the motor technology of a conventional loudspeaker cone, you just might have something.



**MAXIMUM RADIATING SURFACE™
TRANSDUCERS**

MRS™ flat-panel transducers in Infinity's Cascade Series permit unobtrusive speaker enclosures that are nearly as thin as they are narrow. And because the MRS diaphragm functions much like a flat piston, Cascade speakers achieve flat broadband frequency response and uniform on- and off-axis dispersion with minimal breakup, even at high listening levels. That's performance that not even the boxiest of conventional loudspeakers can surpass.



Real-Wood Cherry Veneer

IT'S NOT EASY BEING FLAT.

The appeal of flat-panel transducers has never been more obvious, and the basic technology behind them is straightforward enough. But vintage, earlier flat panels had performance limitations in the low frequencies and were prone to thermal compression. They were also expensive, with several transducers needed for use in high-performance systems. In developing Cascade's MRS transducers, Infinity's engineers incorporated new materials and technologies that have overcome the drawbacks and deliver significant performance benefits.



CMMD cones consist of a stiff aluminum core, deep-anodized on both sides (alumina) for increased strength and rigidity.

CMMD® DIAPHRAGM.

Optimizing the parameters of Cascade's flat-panel diaphragms presented a serious engineering challenge. But by reinforcing



Infinity's patented Ceramic Metal Matrix Diaphragm (CMMD®) – a uniquely rigid lightweight material – with strategic ribs and gussets, Infinity engineers were able to strike the perfect balance between electro-acoustic efficiency and reliability.



DUAL ELLIPTICAL VOICE COILS.

Another flat-panel challenge was finding a way to uniformly drive as much of the diaphragm's radiating surface as possible. A traditional cone is only driven by a small voice coil at its apex, but flat panels require a completely different approach. Infinity engineers developed dual elliptical voice coils for Cascade's MRS drivers. With more than six times the voice-coil-contact of a typical cone transducer, they move the diaphragm much like

an ideal piston, for crystal-clear, resonance-free operation throughout the driver's entire dynamic range.



GREATER DYNAMIC RANGE.

In addition to driving the flat diaphragm more uniformly, the dual elliptical voice coils offer another benefit. The greatly increased surface area of the coils allows them to dissipate heat more efficiently, reducing thermal compression and dramatically increasing the speaker's dynamic range. The result is increased sonic clarity with reduced distortion.

INFINITY MRS
FLAT-PANEL TRANSDUCER



CONVENTIONAL CONE

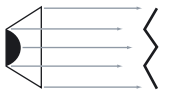

A transducer diaphragm where all points move together and in phase results in less time domain smear, when compared to conventional cone transducers.

MORE UNIFORM RADIATION.

The flat pistonic response of Cascade's MRS drivers sends a cleaner, more uniform sound to listeners' ears than conventional cones. The geometry of a cone inherently creates signals of unequal length with different arrival times, causing what engineers call "time domain smear." Cascade's signals arrive together, for exceptional detail and resolution.



1-1/4"

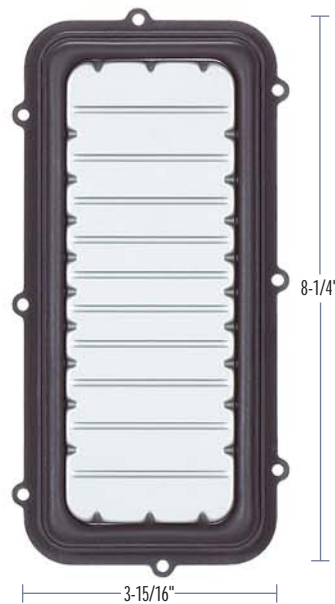

High-Gloss Black



BEYOND THE BOX.

The first Infinity speaker system was also the first in the industry to include a powered subwoofer. This innovation directly enabled the heightened realism of the home theater systems we know today. Most recently, Infinity's Cascade Model Fifteen and Model Twelve make the ubiquitous black-cube subwoofer a thing of the past.

Deep, realistic bass is an essential element of the cinematic experience. But it's just as essential in duplicating the experience of a live musical performance. With the high-performance, small-footprint Model Twelve and the even more powerful and uniquely thin Model Fifteen, Infinity delivers authoritative, distortion-free bass in subwoofers that are easily integrated into any music or home theater system.

Deeper, cleaner bass from room-friendly and more aesthetically pleasing designs. It's a combination that discerning listeners (and their decorators) have long been hoping for.



Both the Model Fifteen and the Model Twelve are also designed for easy integration into your listening room, as well as your décor. Infinity's proprietary Room Adaptive Bass Optimization System™ (R.A.B.O.S.™) allows you to precisely tune the response of your subwoofer to the physical characteristics of your room with just three simple adjustments. And a full complement of inputs and controls makes connection with any movie or music system simplicity itself.

Real-Wood Cherry Veneer



CASCADE[™]
SERIES
Infinity.

FILL YOUR SPACE WITH SOUND,
NOT SPEAKERS.

Design has always been an Infinity hallmark, and Cascade's revolutionary technologies have given our designers even greater freedom. The bulky footprint of the conventional loudspeaker is gone. (With wall-mounted models, the footprint disappears entirely.) Even the powered subwoofer – that most essential of Infinity innovations – has an unexpected new look. Narrow, elegant and (above all) thin, Cascade will surround you with brilliant, captivating sound, without intruding on your space.

Has there ever been a more beautiful way to experience the full excitement of your favorite movies and music?



MODEL NINE
FLOORSTANDING



MODEL SEVEN
FLOORSTANDING



MODEL FIVE
BOOKSHELF/ON-WALL



MODEL THREE V
BOOKSHELF/ON-WALL



MODEL THREE C
CENTER CHANNEL

| | | | | | |
|------------------------------------------|------------------------------------------------------------------------------------|-------------------------------------------------------------------------------|----------------------------------------------------------------------------------------------------------------------------------------------------------------|------------------------------------------------------------------------------------------------------------------------------------------------------------|------------------------------------------------------------------------------------|
| Recommended Amplifier Power Range | 10 – 150 Watts | 10 – 100 Watts | 10 – 100 Watts | 10 – 150 Watts | 10 – 150 Watts |
| Frequency Response | 80Hz – 20kHz (±3dB) 40kHz (-6dB) | 100Hz – 20kHz (±3dB) 40kHz (-6dB) | 100Hz – 20kHz (±3dB) 40kHz (-6dB) | 80Hz – 20kHz (±3dB) 40kHz (-6dB) | 80Hz – 20kHz (±3dB) 40kHz (-6dB) |
| Sensitivity (2.83V @ 1m) | 87dB | 85dB | 85dB | 87dB | 87dB |
| Nominal Impedance | 8 Ohms | 8 Ohms | 8 Ohms | 8 Ohms | 8 Ohms |
| Crossover Frequency | 1,500Hz; 24dB/Octave | 1,800Hz; 24dB/Octave | 1,800Hz; 24dB/Octave | 1,500Hz; 24dB/Octave | 1,500Hz; 24dB/Octave |
| Mid-Bass Driver(s) | Dual 7-3/4" x 3-3/8" (197mm x 85mm) CMMD, [®] magnetically shielded | 7-3/4" x 3-3/8" (197mm x 85mm) CMMD, [®] magnetically shielded | 7-3/4" x 3-3/8" (197mm x 85mm) CMMD, [®] magnetically shielded | Dual 7-3/4" x 3-3/8" (197mm x 85mm) CMMD, [®] magnetically shielded | Dual 7-3/4" x 3-3/8" (197mm x 85mm) CMMD, [®] magnetically shielded |
| High-Frequency Driver | 1" (25mm) CMMD, [®] magnetically shielded | 1" (25mm) CMMD, [®] magnetically shielded | 1" (25mm) CMMD, [®] magnetically shielded | 1" (25mm) CMMD, [®] magnetically shielded | 1" (25mm) CMMD, [®] magnetically shielded |
| Dimensions (H x W x D) | 47" x 10-1/2" x 11-1/2" (1194mm x 267mm x 292mm) | 47" x 10-1/2" x 11-1/2" (1194mm x 267mm x 292mm) | Wall-mounted 22-1/2" x 5-1/2" x 5-1/2" (572mm x 140mm x 140mm) On included base 30-1/4" x 7-3/4" x 8-1/2" (768mm x 197mm x 216mm) | Wall-mounted 30" x 5-1/2" x 5-1/2" (762mm x 140mm x 140mm) On included base 36-5/8" x 7-3/4" x 8-1/2" (930mm x 197mm x 216mm) | 5-1/2" x 30-3/4" x 6" (140mm x 781mm x 152mm) |
| Weight | 28.2 lb (12.8kg) | 24.7 lb (11.2kg) | Wall-mounted – 13.5 lb (6.1kg) On included base – 20.5 lb (9.3kg) | Wall-mounted – 18 lb (8.2kg) On included base – 26 lb (11.8kg) | 18 lb (8.2kg) |



MODEL FIFTEEN
POWERED SUBWOOFER



MODEL TWELVE
POWERED SUBWOOFER

| | | |
|--------------------------------------------------------|-----------------------------------------------|------------------------------------------------|
| Amplifier Output | 800 Watts RMS | 300 Watts RMS |
| Frequency Response | 32Hz – 150Hz (-3dB) 29Hz (-6dB) | 32Hz – 150Hz (-3dB) 28Hz (-6dB) |
| Low-Frequency Driver(s) | Four 6" x 6" (150mm x 150mm) | 10" (250mm) CMMD [®] |
| Crossover Frequency | Adjustable 50Hz – 150Hz or LFE | Adjustable 50Hz – 150Hz or LFE |
| R.A.B.O.S.[™] (Accessory kit included) | Yes | Yes |
| Dimensions (H x W x D) | 13" x 37" x 8-1/2" (330mm x 940mm x 216mm) | 20" x 15" x 13-7/8" (508mm x 381mm x 352mm) |
| Weight | 98 lb (44.5kg) | 42 lb (19kg) |

PREMIUM FINISHES.



REAL-WOOD CHERRY VENEER

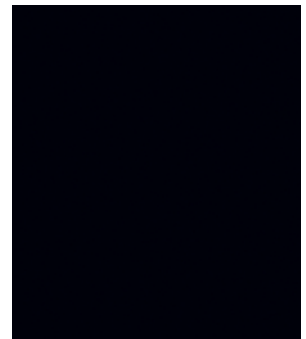

HIGH-GLOSS BLACK